



TAI-SAW TECHNOLOGY CO., LTD.

No. 3, Industrial 2nd Rd., Ping-Chen Industrial District,
Taoyuan, 324, Taiwan, R.O.C.

TEL: 886-3-4690038 FAX: 886-3-4697532

E-mail: tstsales@mail.taisaw.com Web: www.taisaw.com

Product Specifications Approval Sheet

Product Description: Crystal Unit HC49SMD 6.0MHz

TST Part No.: TZ1303A

Customer Part No.: _____

Customer signature required
Company: _____
Division: _____
Approved by : _____
Date: _____

Checked by: _____ Quinton Lo *Quinton Lo*

Approved by: _____ Kelly Huang *Kelly Huang*

Date: _____ 04/13/2010

1. Customer signed back is required before TST can proceed with sample build and receive orders.
2. Orders received without customer signed back will be regarded as agreement on the specifications.
3. Any specifications changes must be approved upon by both parties and a new revision of specifications shall be released to reflect the changes.



TAI-SAW TECHNOLOGY CO., LTD.
HC49SMD 6.0MHz Crystal Unit

MODEL NO.: TZ1303A

REV. NO.: 3.0

Revise:

Rev.	Rev. Page	Rev. Account	Date	Ref. No.	Reviser
3.0	P5	Change Reel Dimension	04/13/10'	2.0	Quinton Lo



TAI-SAW TECHNOLOGY CO., LTD.

No. 3, Industrial 2nd Rd., Ping-Chen Industrial District,
Taoyuan, 324, Taiwan, R.O.C.

TEL: 886-3-4690038 FAX: 886-3-4697532

E-mail: tstsales@mail.taisaw.com Web: www.taisaw.com

HC49SMD 6MHz Crystal Unit

MODEL NO.: TZ1303A

REV. NO.: 3.0

Features:

- Surface Mount Seam Weld Package
- Good Frequency Perturbation and Stability over temperature

RoHS Compliant
Lead free
Lead-free soldering

Description and Applications:

HC49SMD crystal unit for use in wireless telecommunications devices

Electrical Specifications:

TZ1303A	Specification
Nominal Frequency	6.000000 MHz
Mode of Oscillation	Fundamental
Storage Temperature Range	-40°C~+85°C
Operating Temperature Range	-20°C~+70°C
Frequency Stability over Operating Temperature Range	+/-20 ppm (referred to the value at 25°C)
Frequency Make Tolerance (FL)	+/-20 ppm @ 25°C +/- 3°C
Equivalent Series Resistance (ESR)	50 Ω max.
Nominal Drive Level	100 uW typ.
Shunt Capacitance (Co)	7.0 pF MAX
Load Capacitance (CL)	20.0 pF
Aging	+/-3.0 ppm/year
Insulation Resistance	500 MΩ min./DC 100V
Marking	Laser marking

Mechanical Dimensions (mm):

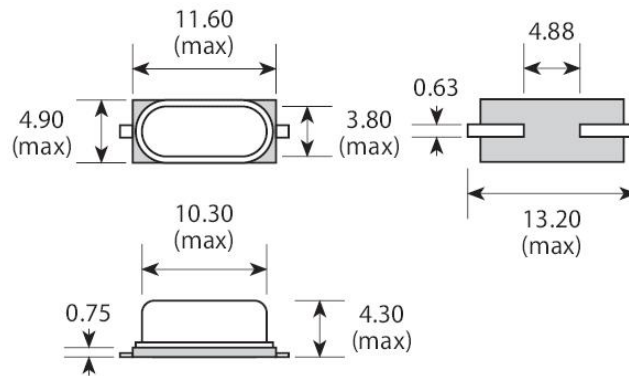

Marking:

Line 1: Frequency

Line 2: TST Logo + Product code + Date Code + Traceability Code (XX)



Product Code Table

Year	2008	2009	2010	2011
	2012	2013	2014	2015
Product Code	<u>Z</u>	<u>Z</u>	<u>z</u>	<u>Z</u>

Date Code Table

WK01	WK02	WK03	WK04	WK05	WK06	WK07	WK08	WK09	WK10	WK11	WK12	WK13
A	B	C	D	E	F	G	H	I	J	K	L	M
WK14	WK15	WK16	WK17	WK18	WK19	WK20	WK21	WK22	WK23	WK24	WK25	WK26
N	O	P	Q	R	S	T	U	V	W	X	Y	Z
WK27	WK28	WK29	WK30	WK31	WK32	WK33	WK34	WK35	WK36	WK37	WK38	WK39
a	b	c	d	e	f	g	h	i	j	k	l	m
WK40	WK41	WK42	WK43	WK44	WK45	WK46	WK47	WK48	WK49	WK50	WK51	WK52
n	o	p	q	r	s	t	u	v	w	x	y	z

PACKING:

1. REEL DIMENSION (Unit: mm)

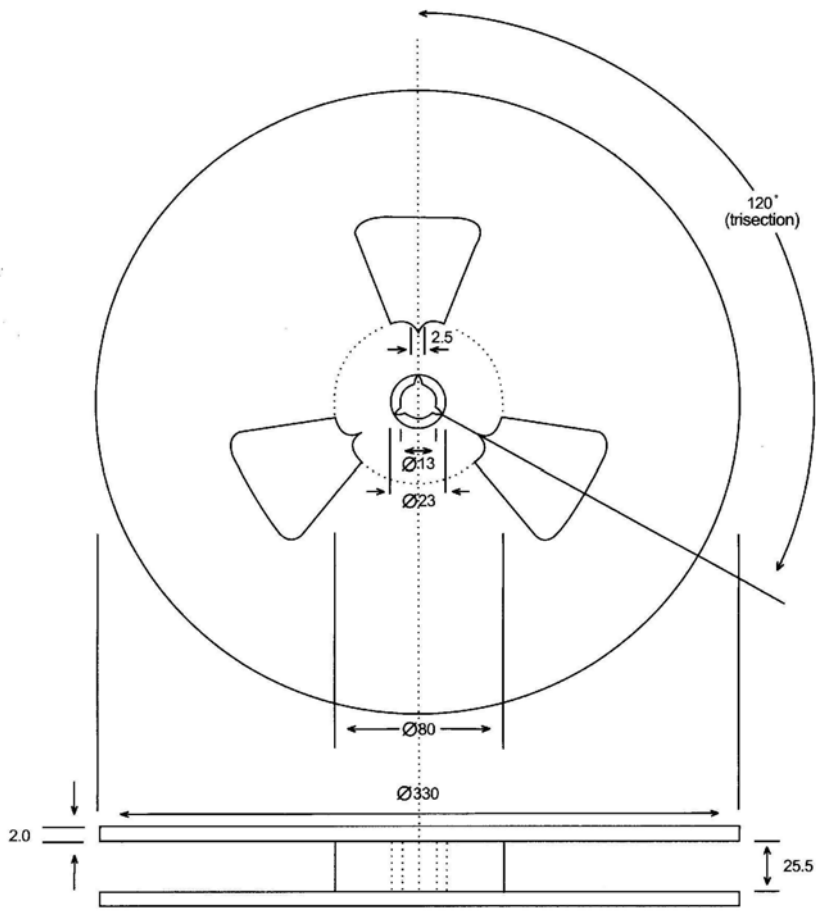

2. TAPE DIMENSION (Unit: mm)

